

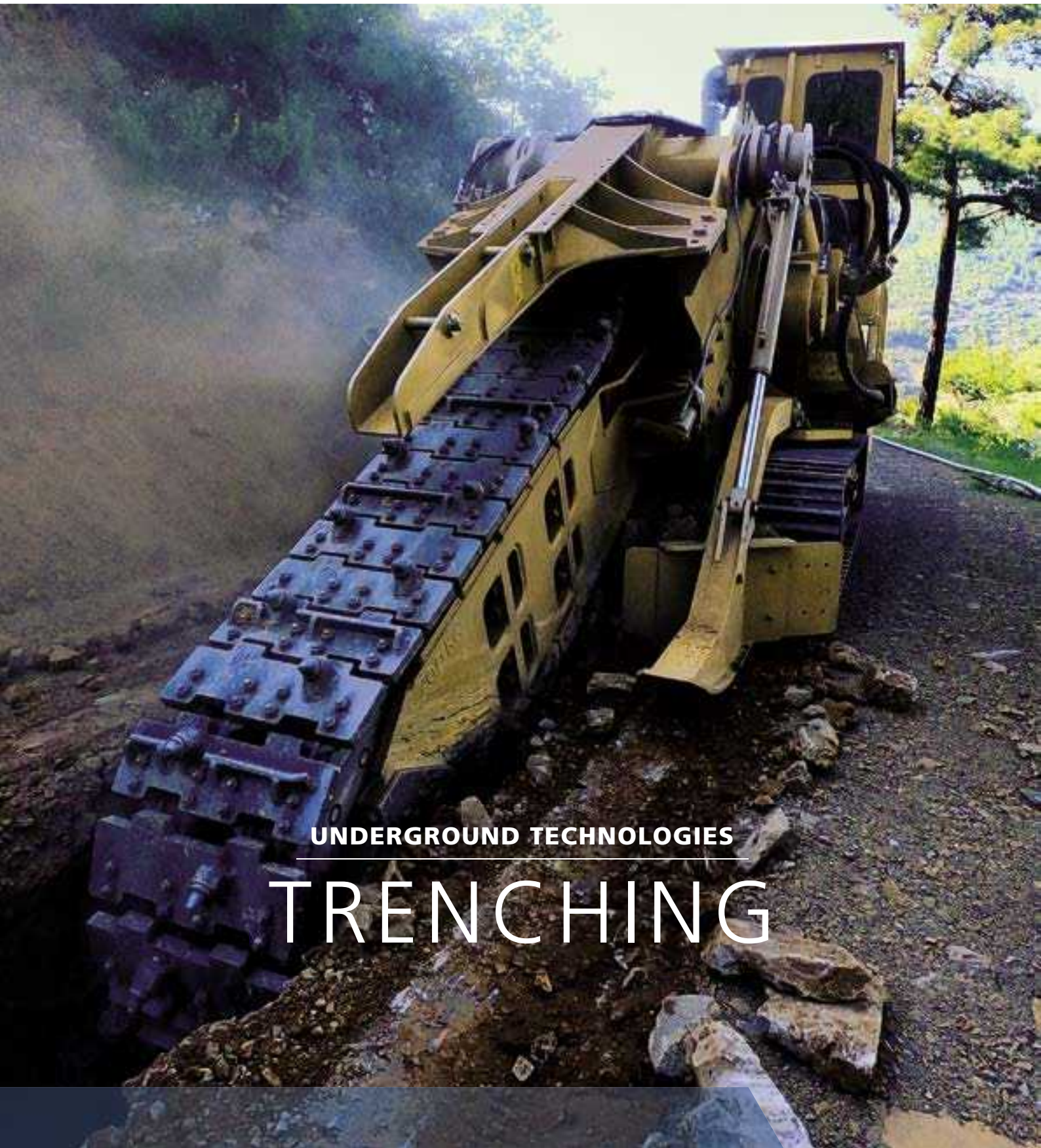

MADE IN GERMANY



UNDERGROUND TECHNOLOGIES

TRENCHING



BETEK TUNGSTEN CARBIDE TOOLS



UNDERGROUND
TECHNOLOGIES

- FOUNDATION DRILLING
- MINING
- TRENCHLESS
- TRENCHING
- TUNGSTUDS
- DRUM CUTTERS

IN USE WORLDWIDE

TUNGSTEN CARBIDE AND STEEL

Steel and carbide are two materials with totally different expansion coefficients when subjected to heat. Nevertheless, it is of steel and tungsten carbide that our tools are made, with tungsten carbide for the wear-resistant tip, and steel for the tool shank. Since tools reach high temperatures during use, extreme tensile stresses are generated. These stresses are absorbed by a special brazing material that joins the tungsten carbide tip to the steel section.

We have developed our own methods and systems for this brazing process, which is carried out on fully automated machines with the process covered in an inert protective gas. Manufacturing parameters are fully monitored and documented to ensure consistent quality. Afterwards, brazing shear strengths are checked to ensure that our "Masters of the construction site" lose no time due to broken tools!



BETEK HIGH-TECH TOOLS



1

CUSTOMER SERVICE

- Efficient, customised solutions based on flexible structures
- Personalised, quick response to customer requirements



2

DEVELOPMENT & CONSTRUCTION

- Quick creation of samples and prototypes
- Competitive pricing thanks to close cooperation with all production units



3

TUNGSTEN CARBIDE MANUFACTURING

- High-purity raw materials are used for high strength
- Consistently high, pore-free tungsten carbide quality through precise process control thanks to years of experience and know-how



4

SOLDERING PRODUCTION UNIT

Production facilities and processes specially developed to perfection by experts in the combination of tungsten carbide and steel



5

AUTOMATION

Maintaining a competitive edge on the global market thanks to a high degree of automation and flexible manufacturing facilities



6

QUALITY ASSURANCE

Continuous quality testing of the entire manufacturing chain all the way up to the installation site, in conformity with DIN ISO 9001:2000 and DIN EN ISO 14001



7

TRAINING

User training courses at BETEK or on-site for sustainable, long-term commercial success and customer satisfaction



8

LOGISTICS

Quick responses thanks to:

- the use of the very latest IT and enhanced logistics networking
- Standard products kept in stock

OUR KNOW-HOW COMBINED WITH STATE-OF-THE-ART PRODUCTION TECHNOLOGIES GUARANTEES THE FINEST QUALITY, MADE IN GERMANY



WELD-ON TEETH

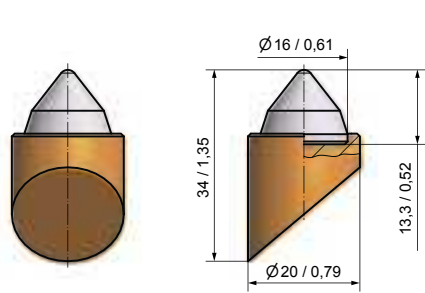

■ **BFZ158**
BFZ3 

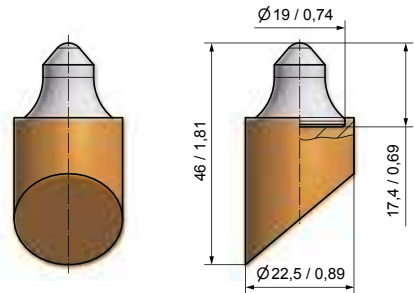

■ **BFZ233**
BFZ6 

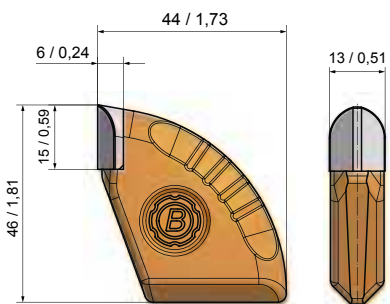

■ **BFZ318**
BFZ46x44x13 

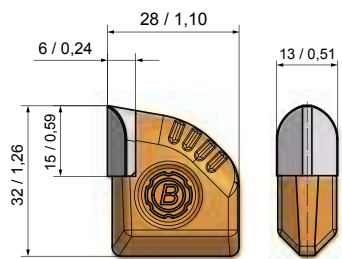

■ **BFZ321**
BFZ32x28x13 

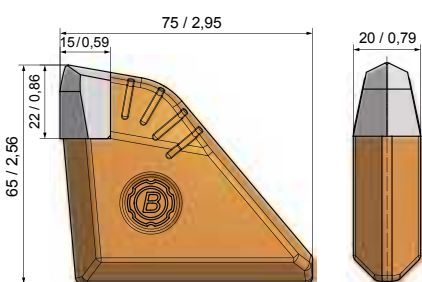

■ **BFZ319**
BFZ75x65x20 

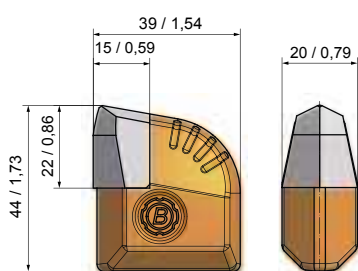

■ **BFZ320**
BFZ44x39x20 

WELD-ON TEETH

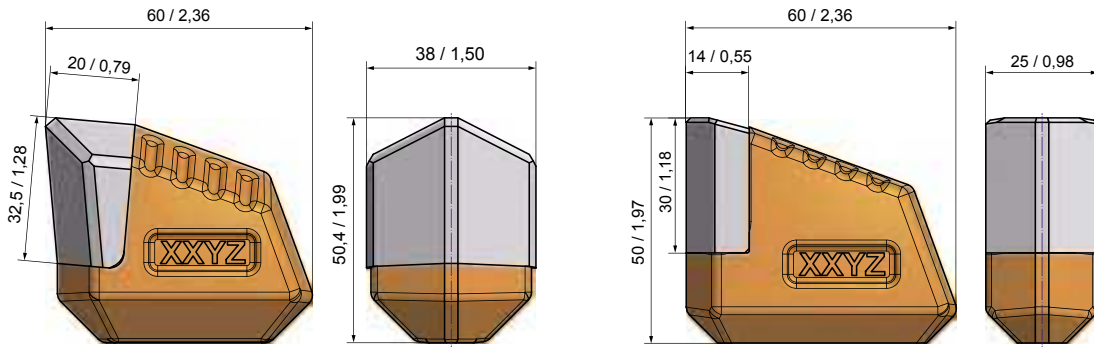

■ **BFZ326**
BFZ38/M 

■ **BBM75**
BBM25x50 



ROUND SHANK CUTTER BITS

► SHANK SYSTEM – Ø 10,1 MM/0,40"

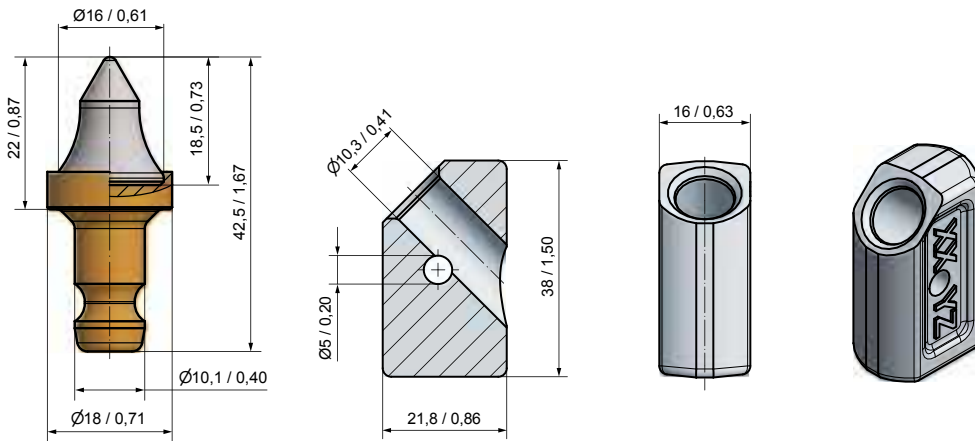

■ **BM92**

BG10S-61.1822



■ **BHR256**

B10.1645



► SHANK SYSTEM – Ø 11,2 MM/0,44"

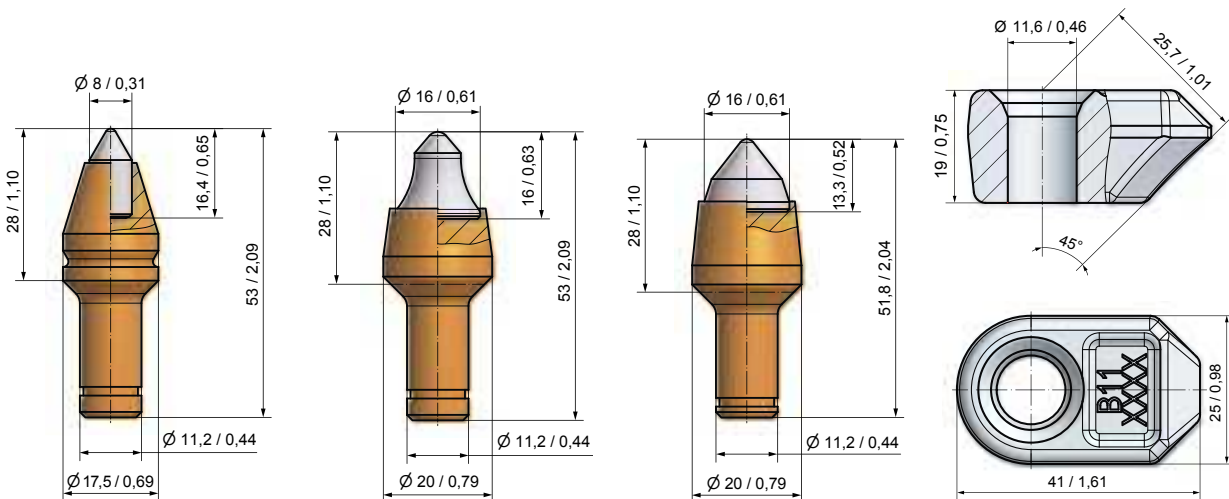

■ **BM11**

BM8-11.3



■ **BM10**

BG11W-61.2028



■ **BM46**

BM3-11.3



■ **BHR03**

B11



ROUND SHANK CUTTER BITS



> SHANK SYSTEM – Ø 14 MM/0,55"

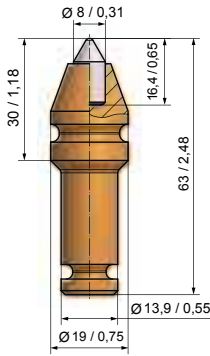

■ **BM84**
BG14X-08.1930

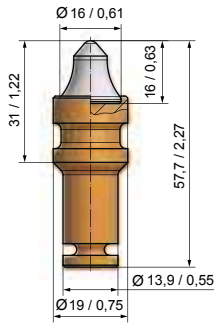

■ **BM44**
BM4-14

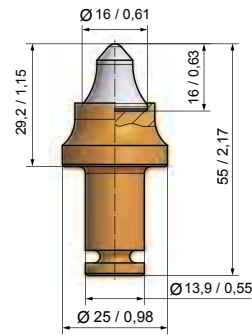

■ **BM76**
BM4-14/TS

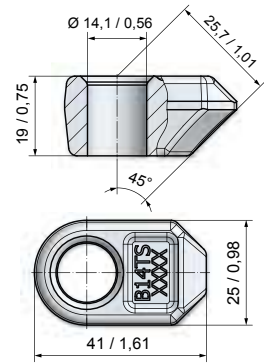

■ **BHR171**
B14-TS



> SHANK SYSTEM – Ø 14 MM/0,55"

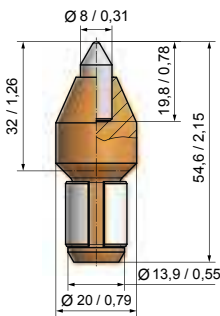

■ **BM56**
BM8-14/2

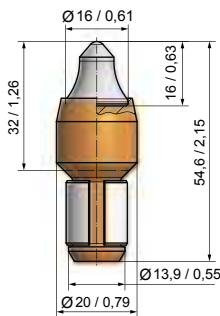

■ **BM55**
BM4-14/2

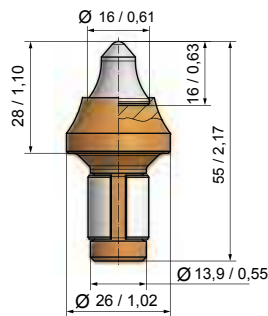

■ **BM82**
BM4-14/3

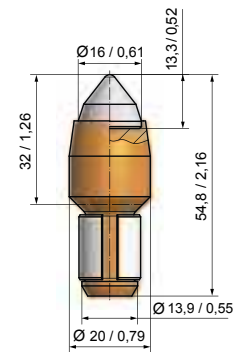

■ **BM60**
BM3-14/H

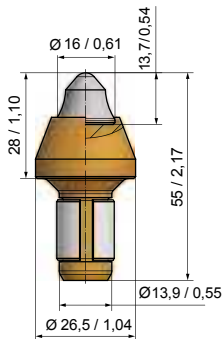

■ **BM93**
BG14H-61.2728

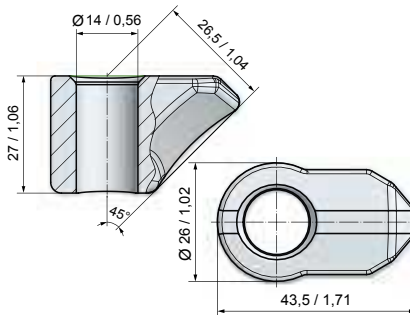

■ **BHR109**
B14

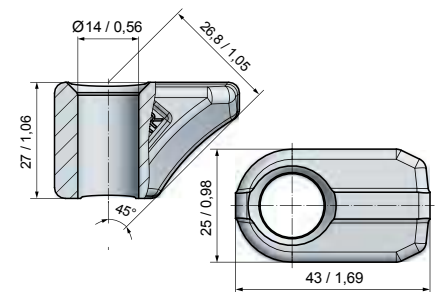

■ **BHR260**
B14.2545



► SHANK SYSTEM – Ø 18,7 MM/0,74"

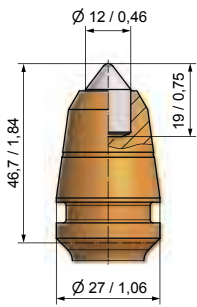
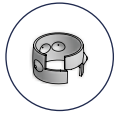

■ **BTR02**
B43HDK12 

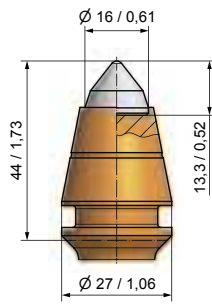

■ **BTR03**
B43/3 

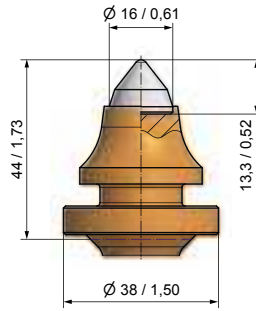

■ **BTR09**
BG19K-60.3844 

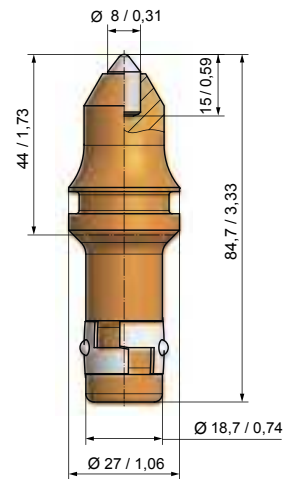

■ **BTR01**
B43K8 

► SHANK SYSTEM – Ø 18,7 MM/0,74"

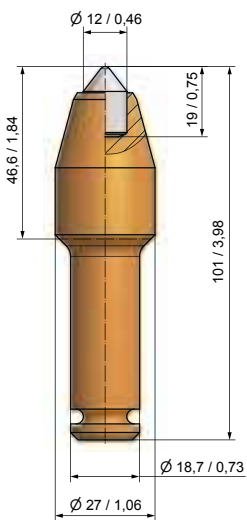

■ **BTR07**
B43K12KS 

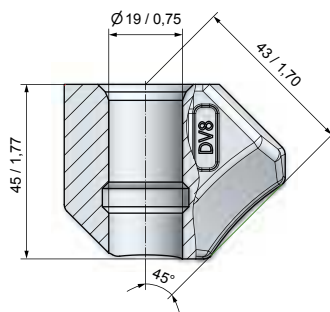

■ **BHR20**
DV8 

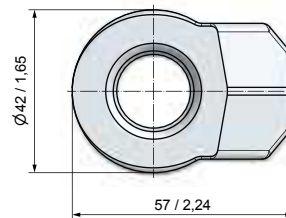

ROUND SHANK CUTTER BITS

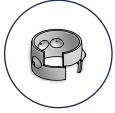

▶ SHANK SYSTEM – Ø 19,4 MM/0,76"

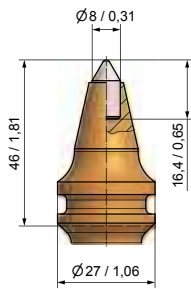

■ **BSK19**
B1K8-K 

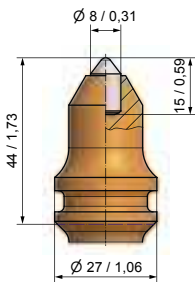

■ **BSK22**
B1K8-K/2 

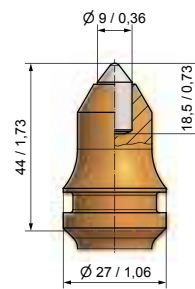

■ **BSK15**
B1K9-K 

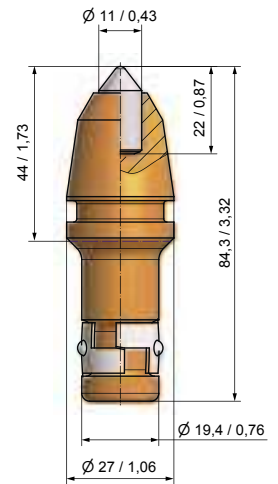

■ **BSK16**
B1HDK11-K 

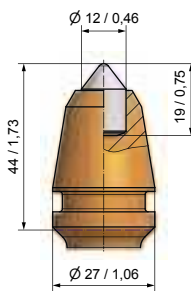

■ **BSK17**
B1HDK12-K 

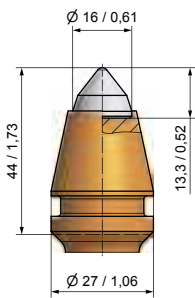

■ **BSK23**
B3-K/2 

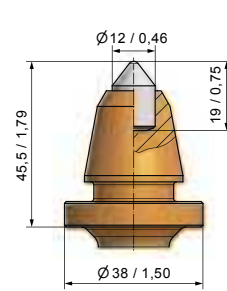

■ **BSK21**
B1-12/38-K 



► SHANK SYSTEM – Ø 19,4 MM/0,76"

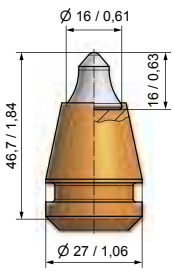

■ BSH204

B4

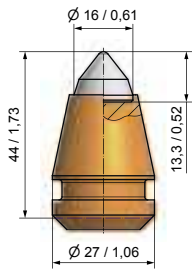

■ BSH09

B3

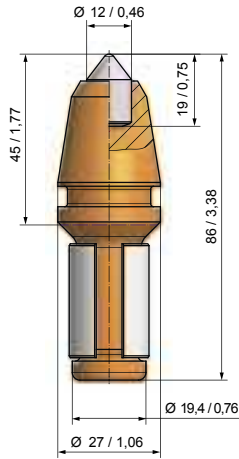

■ BSH05

B1HDK12

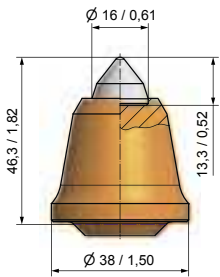

■ BSH211

BG20H-60.3846

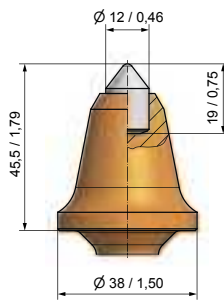

■ BSH210

B1-12/38



► SHANK SYSTEM – Ø 19,4 MM/0,76"

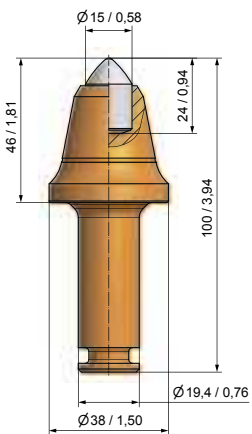

■ BC68

BG20F-15.3846

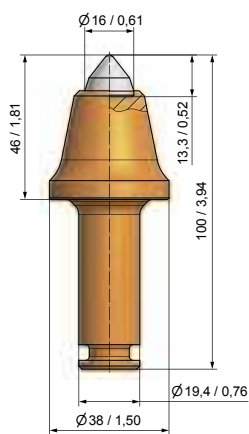

■ BC26

B3KS

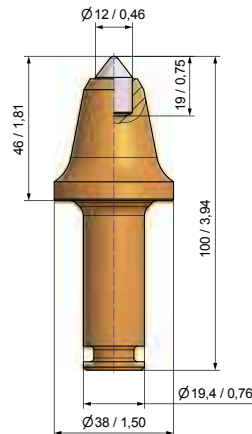

■ BC82

BG20F-12.3846



ROUND SHANK CUTTER BITS

► SHANK SYSTEM – Ø 19,4 MM/0,76"

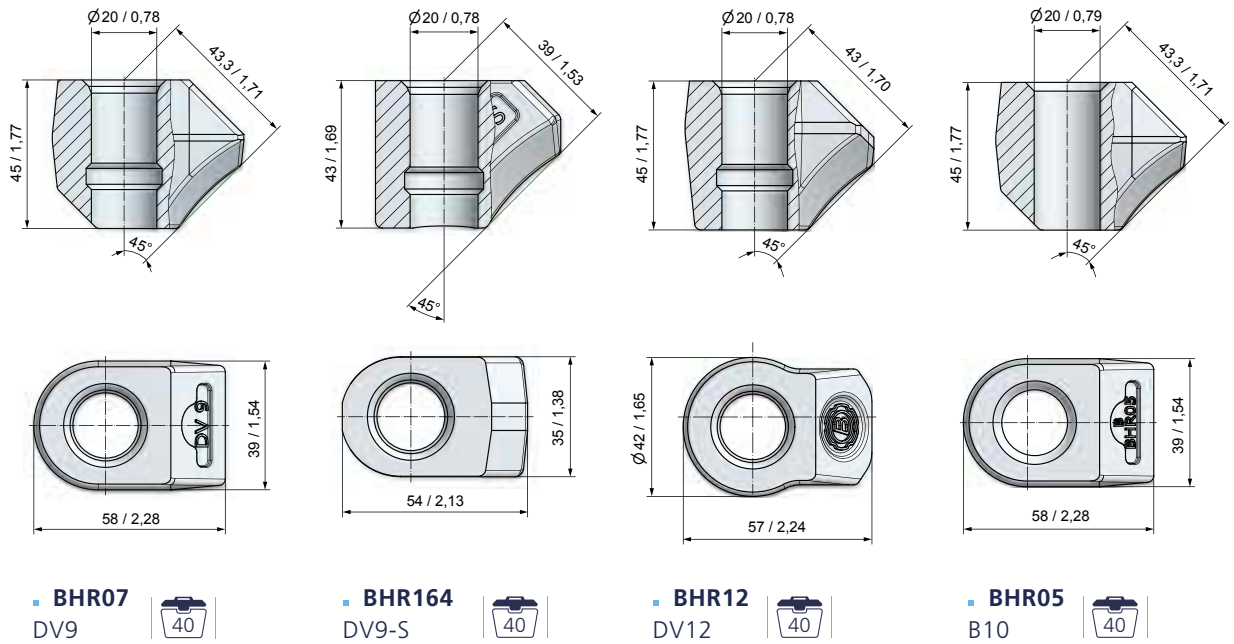

► SHANK SYSTEM – Ø 22 MM/0,87"

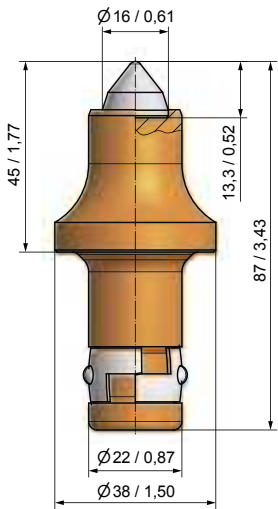
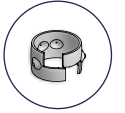

■ **BC58**
B3S/22-K 

► SHANK SYSTEM – Ø 22 MM/0,87"

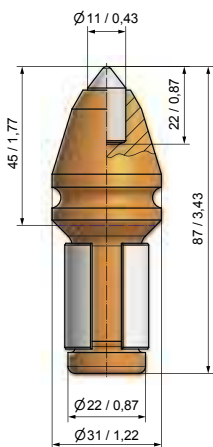
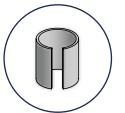

■ **BC05**
B1HDK11/22 

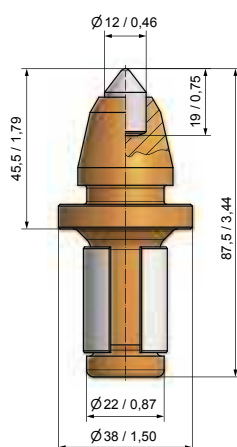

■ **BC60**
B1-12/22 

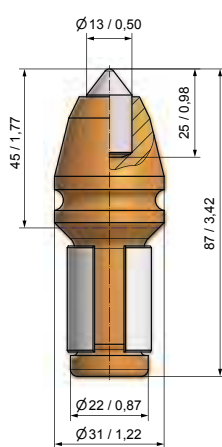

■ **BC06**
B1HDK13/22 

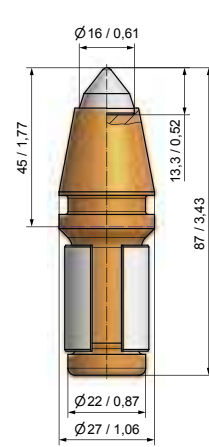

■ **BC49**
B3/22 

ROUND SHANK CUTTER BITS



▶ SHANK SYSTEM – Ø 22 MM/0,87"

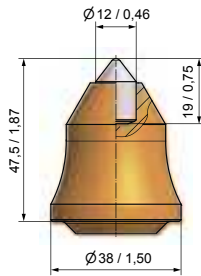

■ **BC64**
B1-12/22-B 

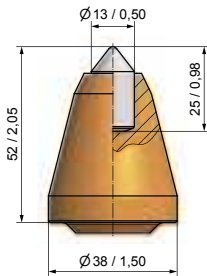

■ **BC14**
BG22H-13.3852 

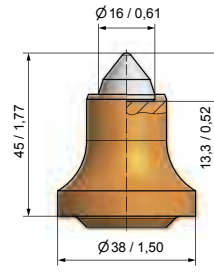

■ **BC41**
B3S/22 

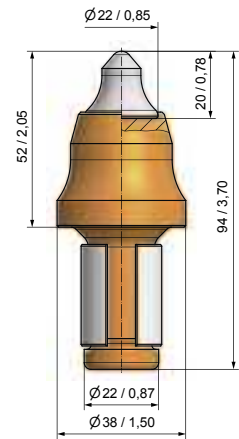

■ **BC03**
B8S/22 

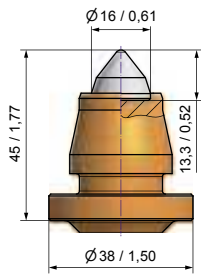

■ **BC81**
BG22H-60.3845 

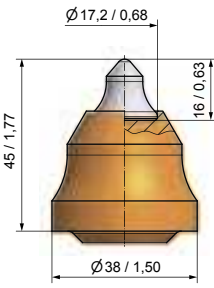

■ **BC04**
B5S/22 

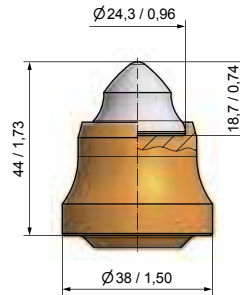

■ **BC43**
B9/22 



► SHANK SYSTEM – Ø 22 MM/0,87"

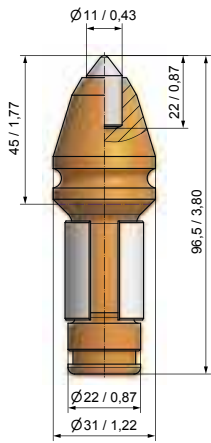

■ **BC01**
B1HDK11/22/S 

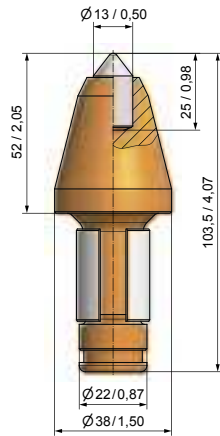

■ **BC15**
B1HD38/13/22/S 

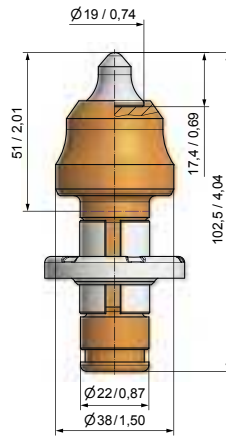

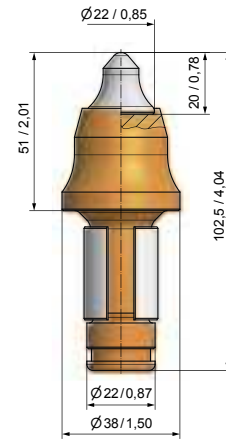

■ **BC61**
B6V/22/S 

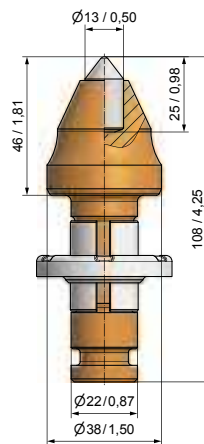
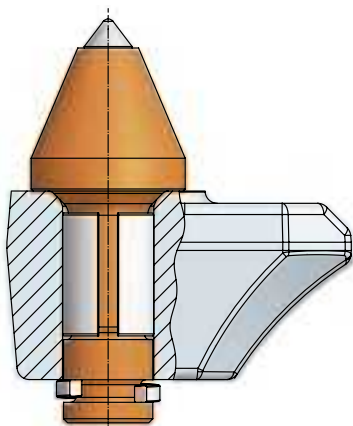
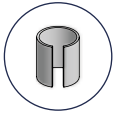

■ **BC44**
B8/22-S 

► SHANK SYSTEM – Ø 22 MM/0,87"



■ **BC79**
BG22HF-13.3851 

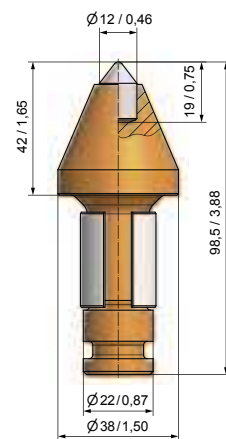

■ **BC36**
B1-12/22/SI26 

ROUND SHANK CUTTER BITS



► SHANK SYSTEM – Ø 22 MM/0,87"

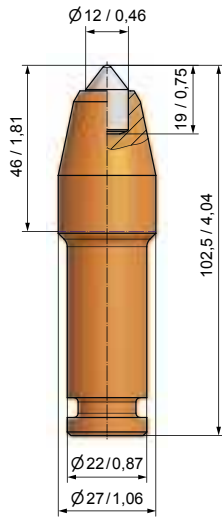

■ **BC39**
B1-12KS/22

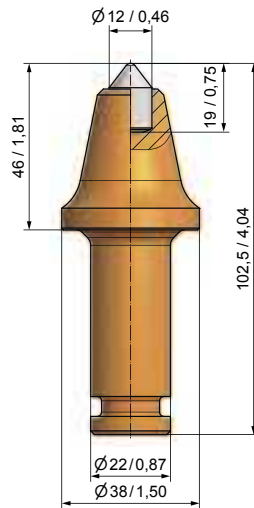

■ **BC62**
B1-12/38KS22

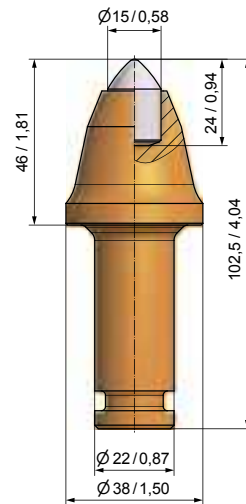

■ **BC77**
BG22F-15.3846

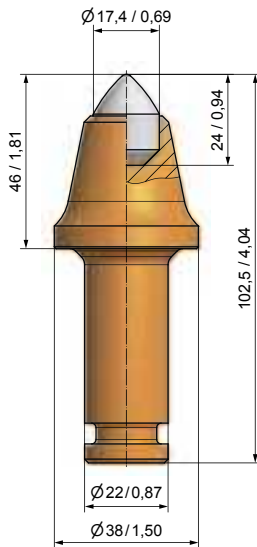

■ **BC56**
B1-17KS22

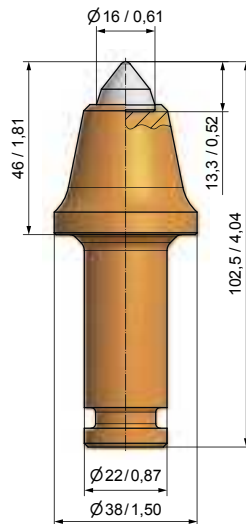

■ **BC33**
B3KS22

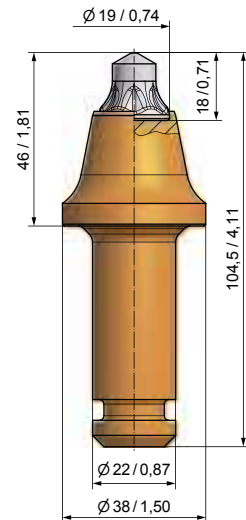

■ **BC78**
BG22F-65.3846

► SHANK SYSTEM – Ø 22 MM/0,87"

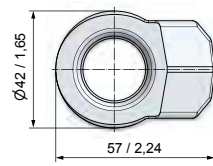
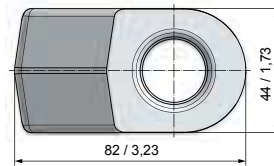
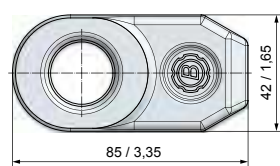
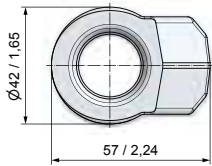
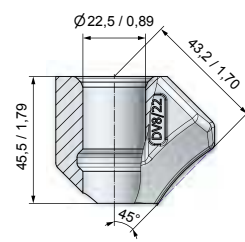
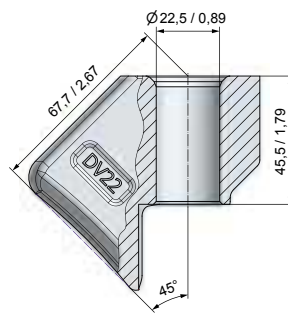
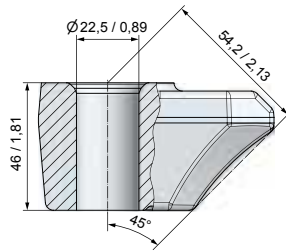
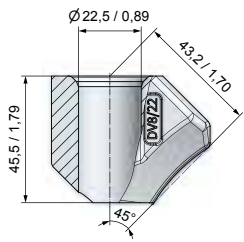

■ BHR27
DV8/22



■ BHR120
B22S



■ BHR30
DV22



■ BHR176
DV8/22-K



ROUND SHANK CUTTER BITS

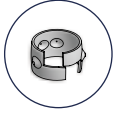

▶ SHANK SYSTEM – Ø 25 MM/1"

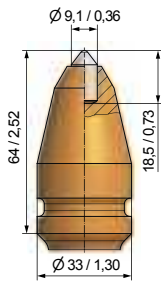

■ **BTK01**
BG25-09.3364

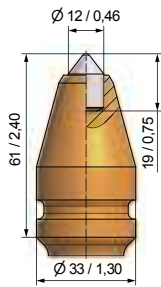

■ **BTK03**
BG25K-12.3361

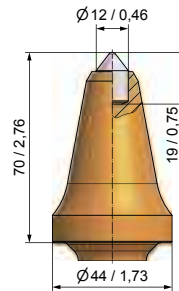

■ **BTK141**
BG25K-12.4470A

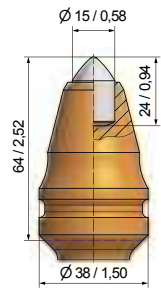

■ **BTK10**
BG25K-15.3864

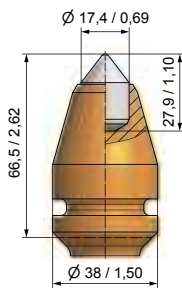

■ **BTK70**
BG25K-17.3867

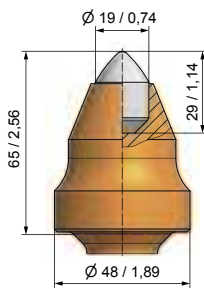

■ **BTK54**
BG25K-19.4865

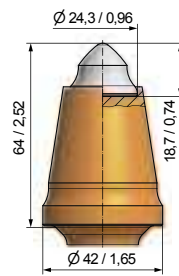

■ **BTK87**
BG25K-68.4264

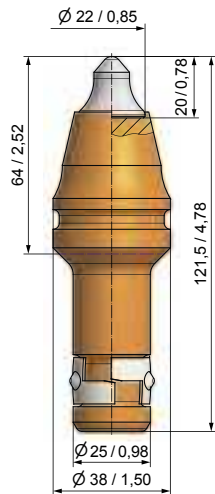

■ **BTK20**
BG25K-67.3864

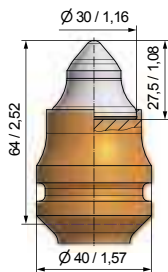

■ **BTK23**
BG25K-69.4064

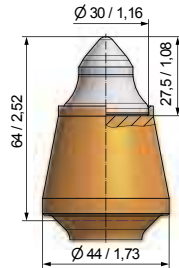

■ **BTK26**
BG25K-69.4464

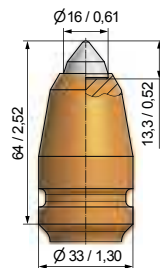

■ **BTK16**
BG25K-60.3364







ROUND SHANK CUTTER BITS

▶ SHANK SYSTEM – Ø 25 MM/1"

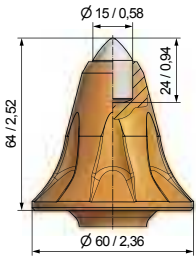
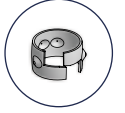

■ **BTK81**
B40HDS/60

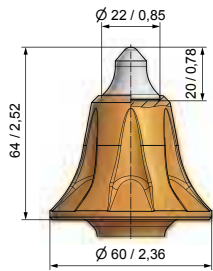

■ **BTK80**
B4022/60

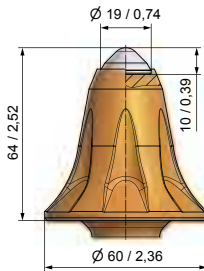

■ **BTK82**
B40SG/60

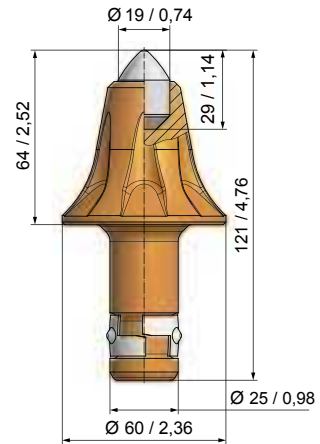

■ **BTK89**
BG25K-19.6064

▶ SHANK SYSTEM – Ø 25 MM/1"

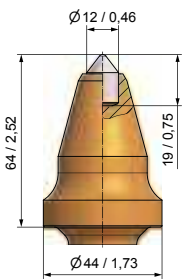

■ **BTK142**
BG25F-12.4464A

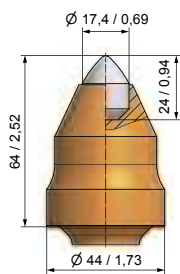

■ **BTK11**
BG25F-17.4464

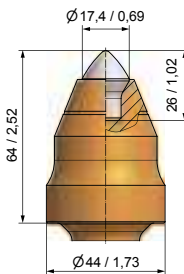

■ **BTK135**
BG25F-70.4464

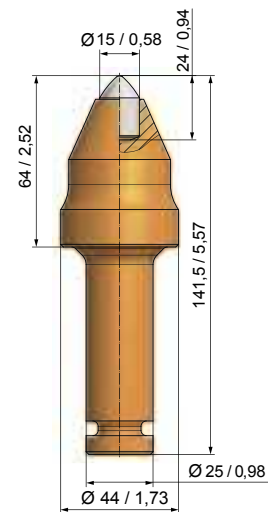

■ **BTK29**
BG25F-15.4464

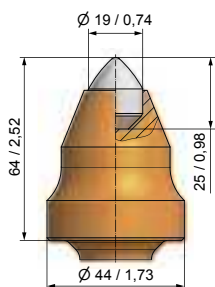

■ **BTK14**
BG25F-19.4464

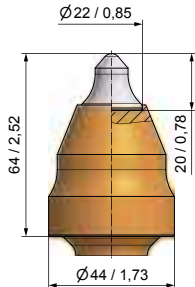

■ **BTK43**
BG25F-67.4464

ROUND SHANK CUTTER BITS



▶ SHANK SYSTEM – Ø 25 MM/1"
GAUGE 64 MM/2,5"

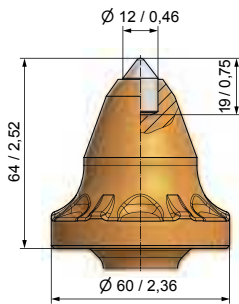

■ **BTK114**
BG25F-12.6064

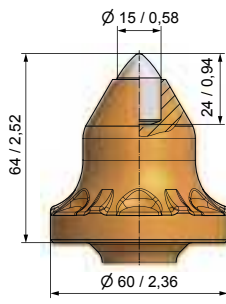

■ **BTK120**
BG25F-15.6064

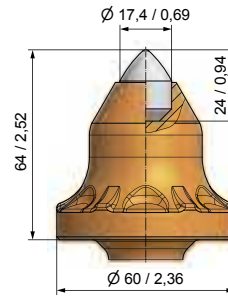

■ **BTK121**
BG25F-17.6064

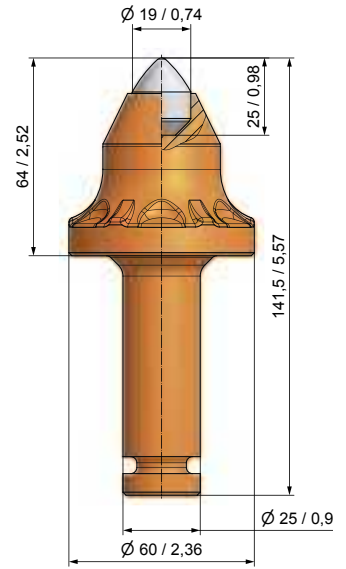

■ **BTK122**
BG25F-19.6064

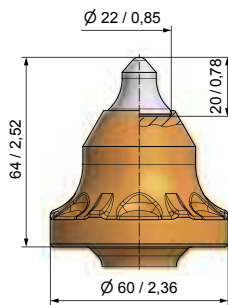

■ **BTK123**
BG25F-67.6064

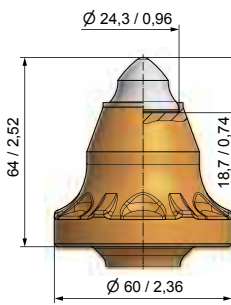

■ **BTK124**
BG25F-68.6064

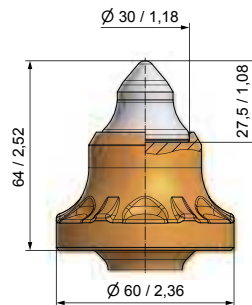

■ **BTK125**
BG25F-69.6064A

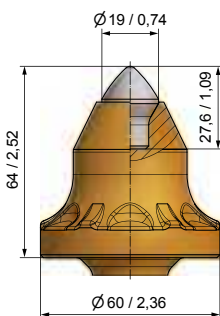

■ **BTK143**
BG25F-72.6064

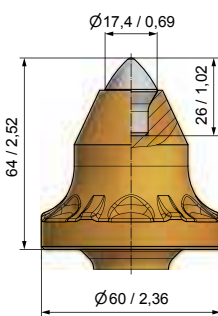

■ **BTK150**
BG25F-70.6064

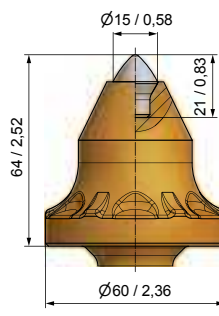

■ **BTK151**
BG25F-76.6064

► SHANK SYSTEM – Ø 25 MM/1"
GAUGE 76 MM/3,0"

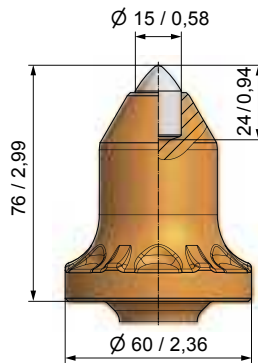
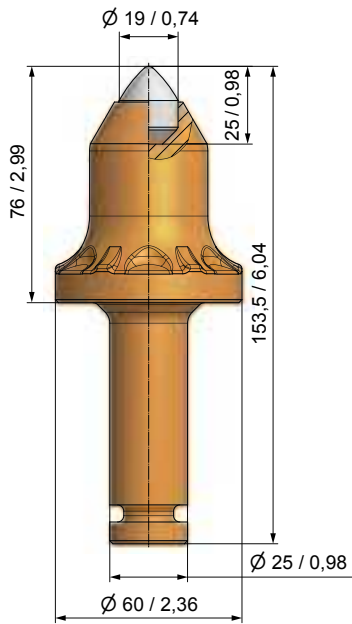

■ **BTK113**
BG25F-15.6076

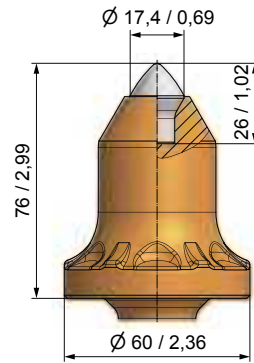

■ **BTK126**
BG25F-70.6076A

■ **BTK127**
BG25F-19.6076A





► SHANK SYSTEM – Ø 25 MM/1"

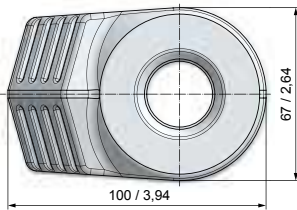
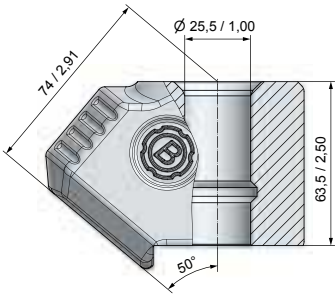

■ **BHR186**
B25.6750

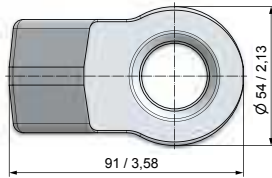
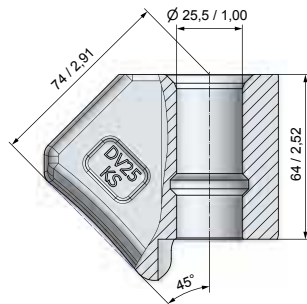

■ **BHR121**
DV25KS

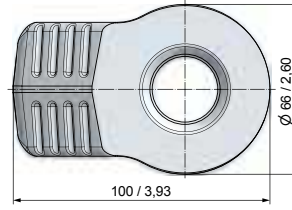
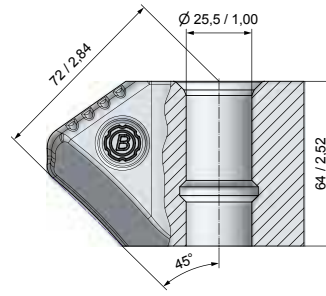

■ **BHR34**
DV40VS

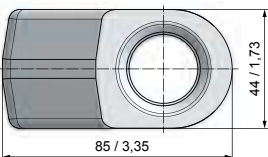
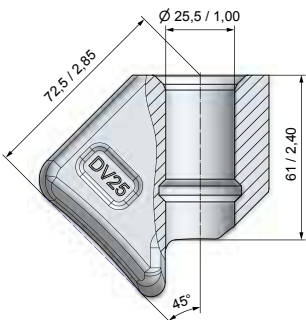

■ **BHR31**
DV25

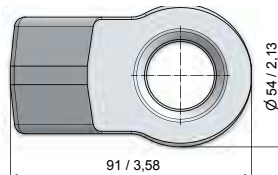
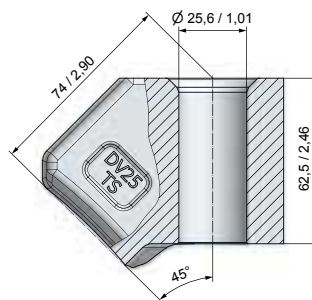

■ **BHR145**
DV25TS



ROUND SHANK CUTTER BITS



▶ SHANK SYSTEM – Ø 38/30 MM-1,5/1,18" GAUGE 64 MM/2,5"

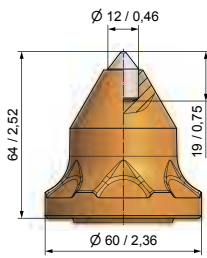

■ **BKS165**
BS38W-12.6064A

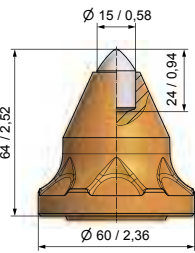

■ **BKS144**
BS38W-15.6064

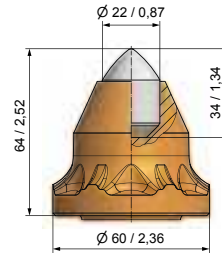

■ **BKS162**
BS38W-22.6064

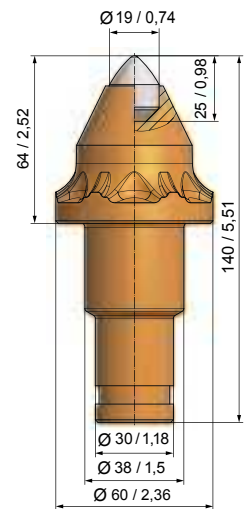

■ **BKS151**
BS38W-19.6064

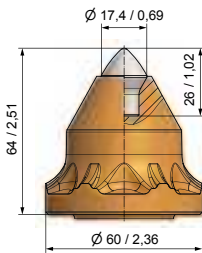

■ **BKS163**
BS38W-70.6064

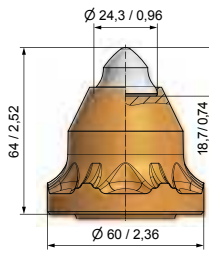

■ **BKS160**
BS38W-68.6064

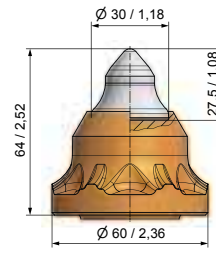

■ **BKS161**
BS38W-69.6064



▶ SHANK SYSTEM – Ø 38/30 MM-1,5/1,18" GAUGE 70 MM/2,75"

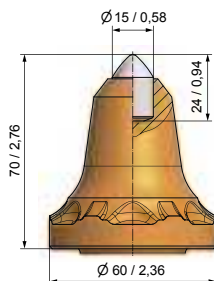

■ **BKS168**
BS38W-15.6070

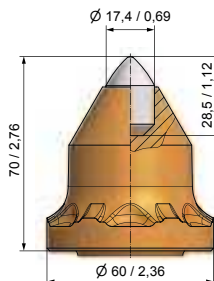

■ **BKS166**
BS38W-17.6070

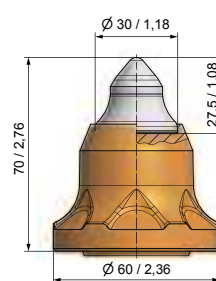

■ **BKS167**
BS38W-69.6070A



► SHANK SYSTEM – Ø 38/30 MM-1,5/1,18" GAUGE 77 MM/3,0"

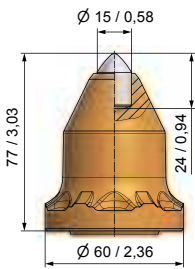

■ **BKS169**
BS38W-15.6077A

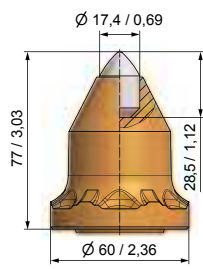

■ **BKS171**
BS38W-17.6077

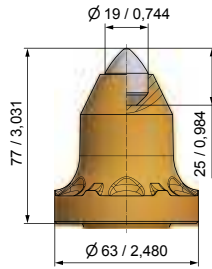

■ **BKS172**
BS38W-19.6377

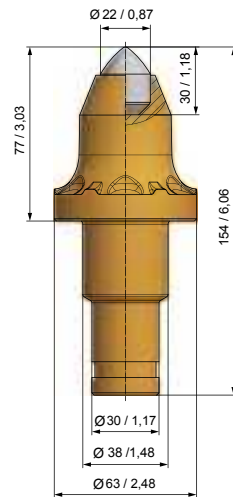

■ **BKS170**
BS38W-22.6377

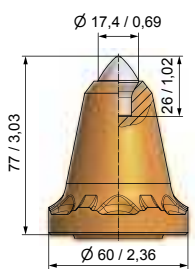

■ **BKS174**
BS38W-70.6077

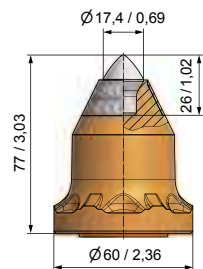

■ **BKS193**
BS38W-70.6077P

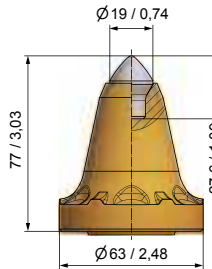

■ **BKS175**
BS38W-72.6377

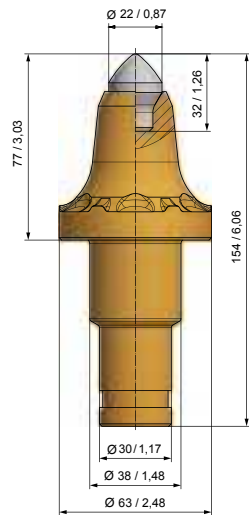

■ **BKS158**
BS38W-73.6377

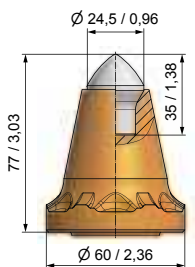

■ **BKS176**
BS38W-71.6077

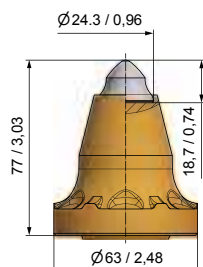

■ **BKS178**
BS38W-68.6377

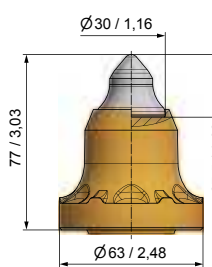

■ **BKS177**
BS38W-69.6377



ROUND SHANK CUTTER BITS



► SHANK SYSTEM – Ø 38/30 MM-1,5/1,18"
GAUGE 89 MM/3,5"

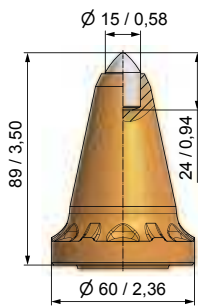

■ **BKS179**
BS38W-15.6089

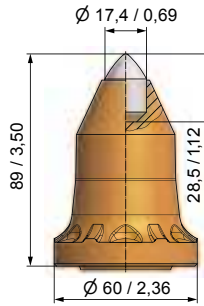

■ **BKS180**
BS38W-17.6089

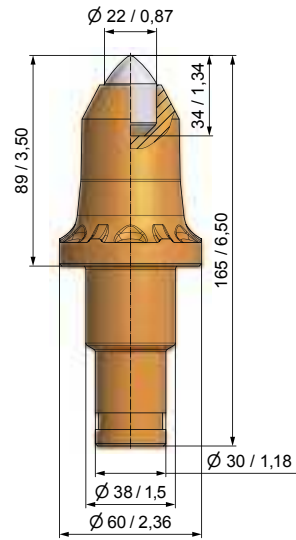

■ **BKS183**
BS38W-22.6089

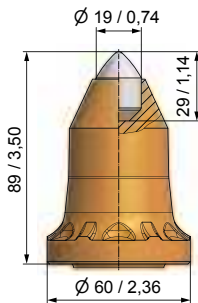

■ **BKS181**
BS38W-19.6089

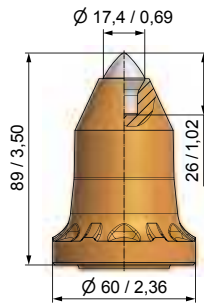

■ **BKS182**
BS38W-70.6089





ROUND SHANK CUTTER BITS



► SHANK SYSTEM – Ø 38/30 MM-1,5/1,18"
GAUGE 64/68 MM-2,5/2,68"

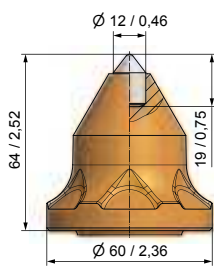

■ BKF27
BS38F-12.6064

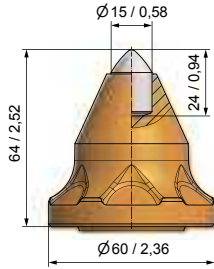

■ BKF24
BS38F-15.6064

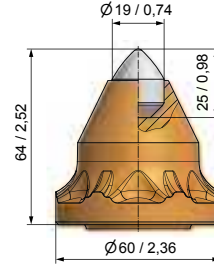

■ BKF22
BS38F-19.6064

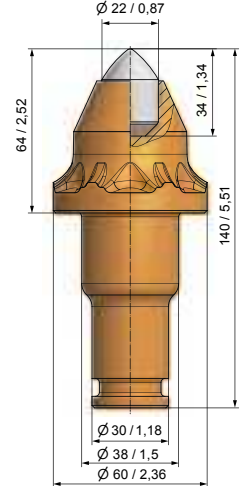

■ BKF26
BS38F-22.6064

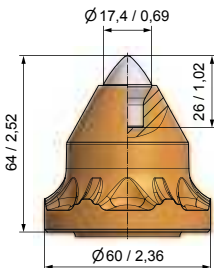

■ BKF25
BS38F-70.6064

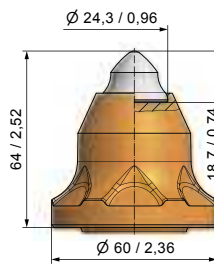

■ BKF28
BS38F-68.6064

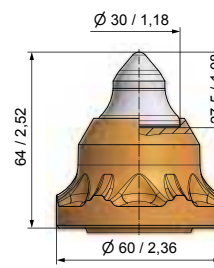

■ BKF29
BS38F-69.6064

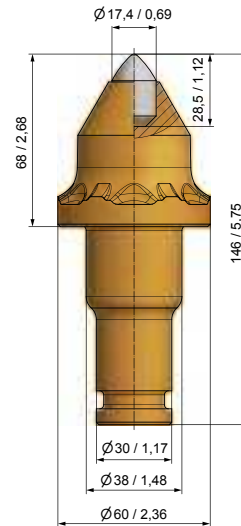

■ BKF63
BS38F-17.6068

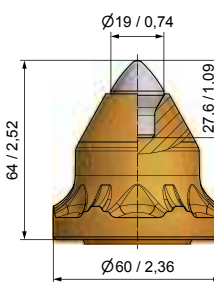

■ BKF65
BS38F-72.6064

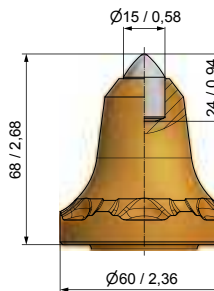

■ BKF62
BS38F-15.6068

► SHANK SYSTEM – Ø 38/30 MM-1,5/1,18" GAUGE 77 MM/3,0"

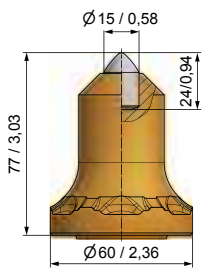

■ BKF32

BS38F-15.6077

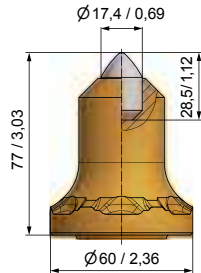

■ BKF33

BS38F-17.6077

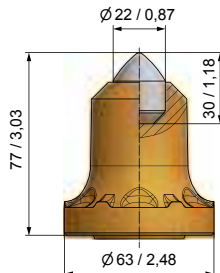

■ BKF31

BS38F-22.6377

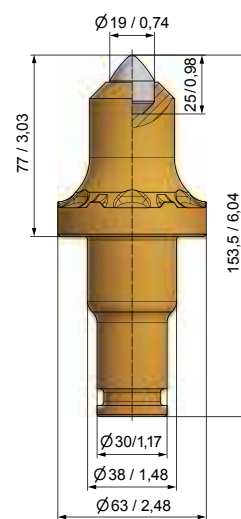

■ BKF30

BS38F-19.6377

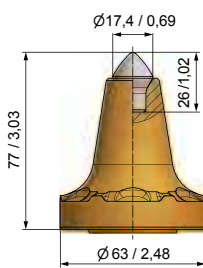

■ BKF40S

BS38F-70.6377S

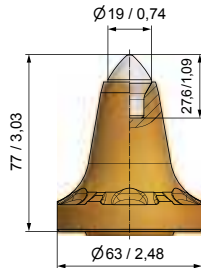

■ BKF39S

BS38F-72.6377S

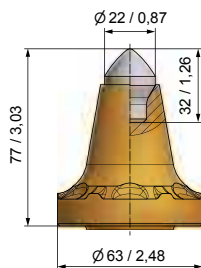

■ BKF38S

BS38F-71.6377S

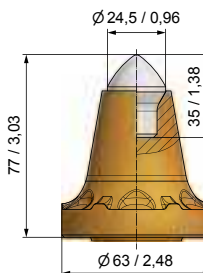

■ BKF36S

BS38F-71.6377S

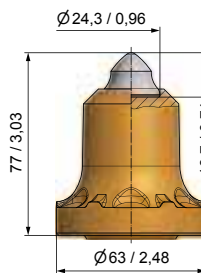

■ BKF34

BS38F-68.6377

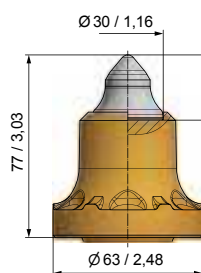

■ BKF37

BS38F-69.6377



ROUND SHANK CUTTER BITS



▶ SHANK SYSTEM – Ø 38/30 MM-1,5/1,18" GAUGE 89 MM/3,5"

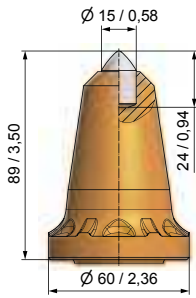

■ BKF41

BS38F-15.6089

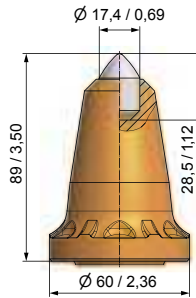

■ BKF42

BS38F-17.6089

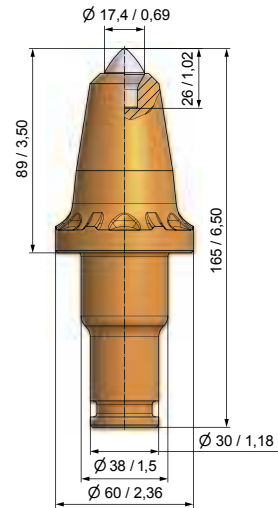

■ BKF45

BS38F-70.6089

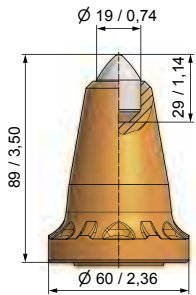

■ BKF43

BS38F-19.6089

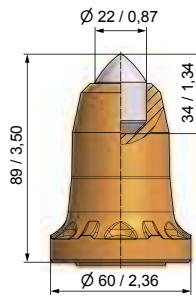

■ BKF44

BS38F-22.6089



► SHANK SYSTEM – Ø 38/30 MM-1,5/1,18"

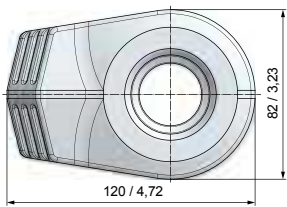
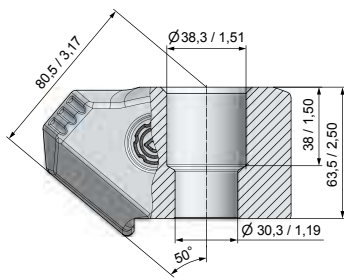

■ **BHR187**
B3830.8250

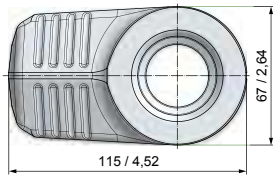
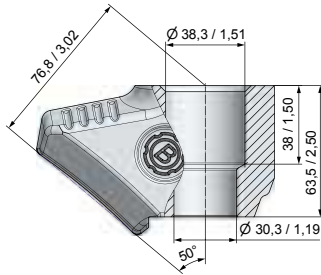

■ **BHR188**
B3830.6750

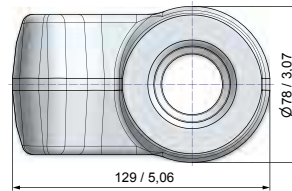
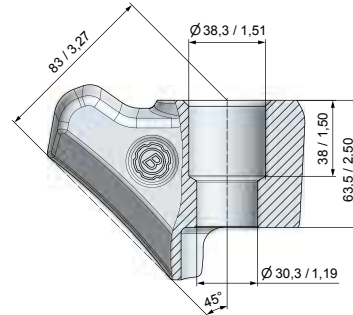

■ **BHR204**
B3830.7845

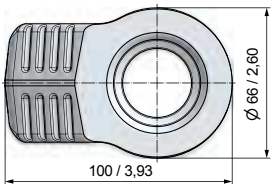
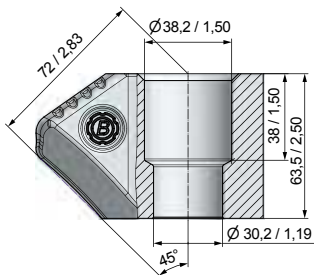

■ **BHR38**
B43H



ACCESSORIES



■ **BZ44**
Bit extractor for Mini bit



■ **BZ42**
Bit extractor for BSH and BC-Series



■ **BZ43**
Bit extractor for BSH, BC and BSK with lock ring



■ **BZ38**
Wedge puller for shaft diameter 20-25



■ **BZ33**
Assembly tool for SI36



■ **BZ31**
Disassembly tool for SI36 and SR90



■ **BZ41**
Assembly tool for SI26



■ **BZ32**
Disassembly tool for SI26



■ **BZ22**
Bit puller for BTK-Series



■ **BZ37**
Assembly tool for SI79/K



■ **BZ36**
Disassembly tool for SI79/K



■ **BZ05**
Bit puller for head diameter 60



■ **BZ35**
Assembly tool for SI239



■ **BZ34**
Disassembly tool for SI239



■ **BZ39**
Wedge puller for shaft diameter 30-38



■ **SRZ02**
Plier for SR83/1, SR61 and SR54



■ **BZ12**
Bit puller for BKH-Series



■ **BZ18**
Bit puller with copper disk for BKH-Series



■ **BZ16**
Bit extractor for Roll pin with diameter 10



■ **BZ30**
Bit extractor for Roll pin with diameter 16



■ **BZ40**
Wedge puller for stepshank 43/35

EXTENSIVE WEAR PROTECTION



► OVERVIEW

Betek can provide the appropriate stud welding machine for the TungStuds wear protection system.

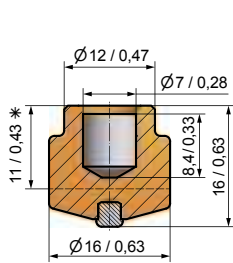

■ **BTS01** BTSD16/16 

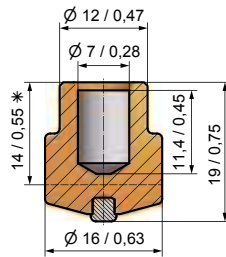

■ **BTS02** BTSD16/19 

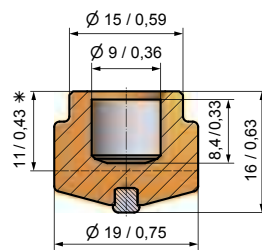

■ **BTS03** BTSD19/16 

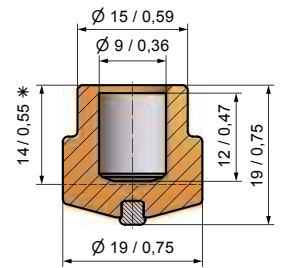

■ **BTS04** BTSD19/19 

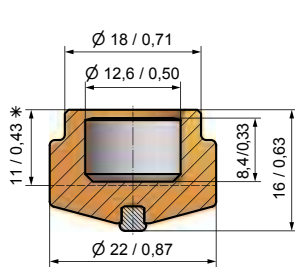

■ **BTS05** BTSD22/16 

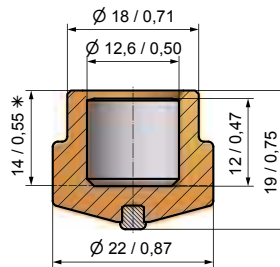

■ **BTS06** BTSD22/19 

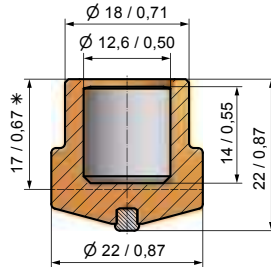

■ **BTS07** BTSD22/22 

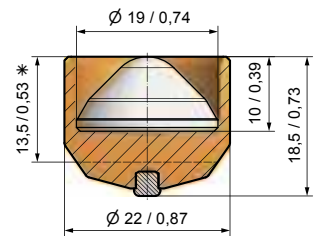

■ **BTS08** BTSD22/18,5SG 

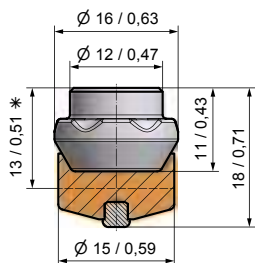

■ **BTS10B** BTSD16/18B 

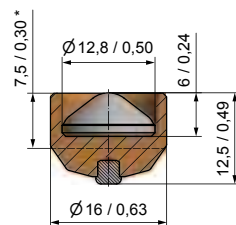

■ **BTS20** BTSD16/12,5SG 

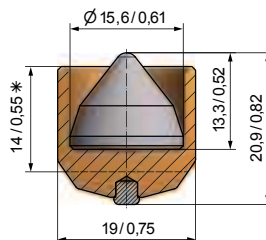

■ **BTS100** BTSD19/15,6SG 

*Height after welding

► BTS-PLATES

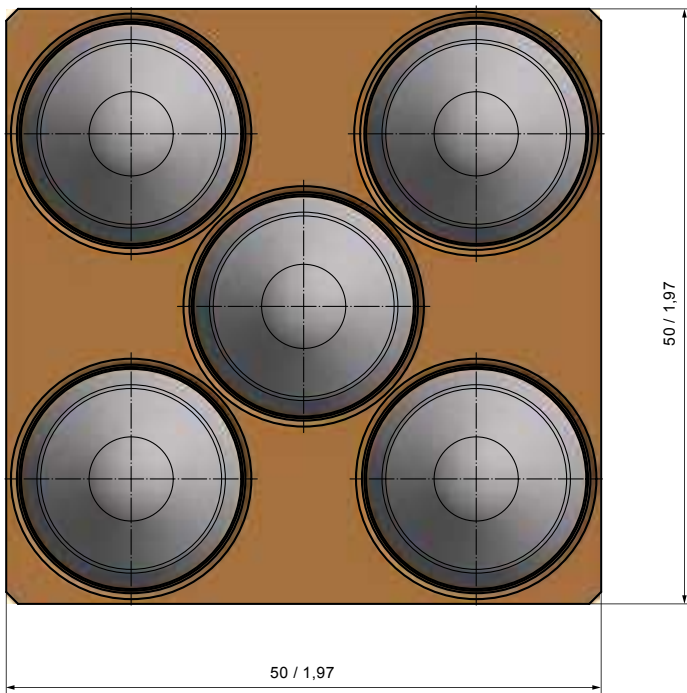
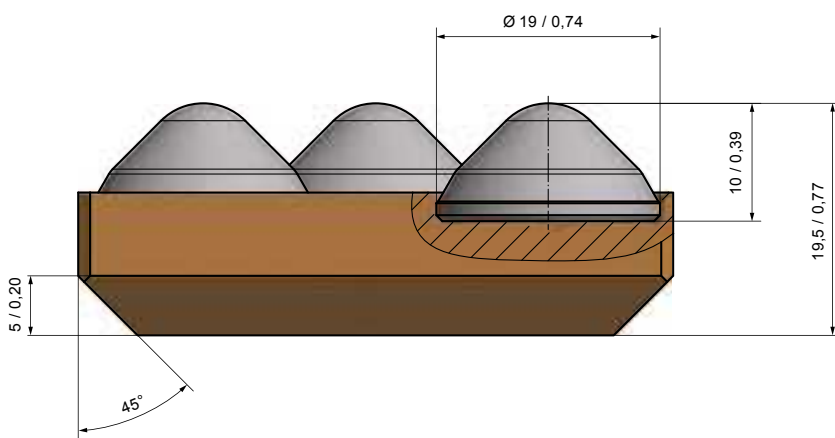

DIMENSIONS

Width in mm	Length in mm
50	50
75	75
100	100
125	125
150	150

Other sizes on request

EXTENSIVE WEAR PROTECTION

> WELDING PROCESS

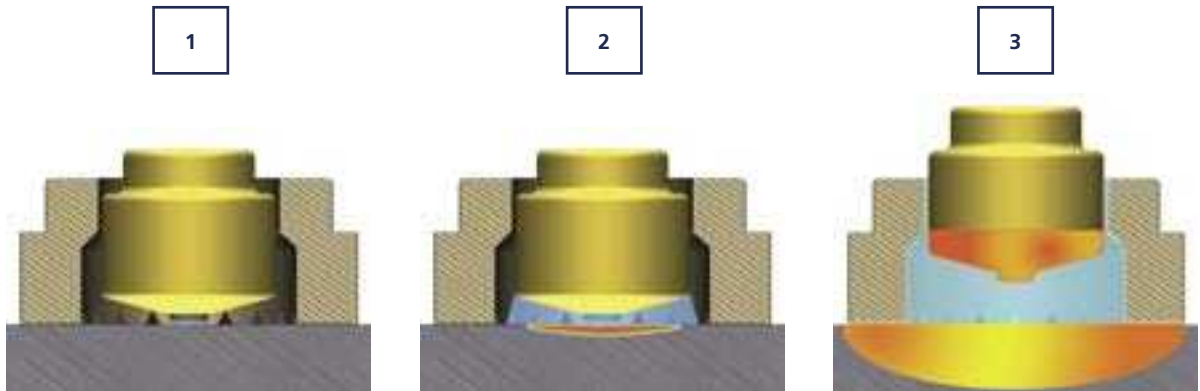

- The TungStud should be placed on the steel surface
- The ceramic ferrule protects the welding area around

- Current flow is applied
- The TungStud raises up as soon as the arc ignites

- The arc causes a specific melting of the TungStud and the steel surface

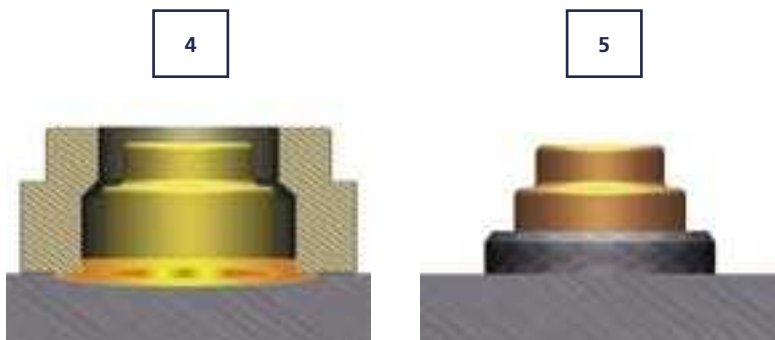

- The TungStud plunges into the melted steel surface

- The welding connection between TungStud and steel surface is completed

BENEFITS

- Wear resistant thanks to the carbide core
- Quick welding process
- Suitable for uneven surfaces
- Simply replaceable
- Less maintenance > Higher productivity
- Less downtime > Cost reduction

PERFORMANCE

› CUTTING WEAR PROTECTION

- Grid pattern is recommended
- Cutting wear protection due to the conical carbide shape

EXTENSIVE WEAR PROTECTION



› ROCK BOX EFFECT

- Grid pattern is recommended
- Rock-Box-Effect due to the cylindrical carbide shape

EXTENSIVE WEAR PROTECTION



APPLICATION

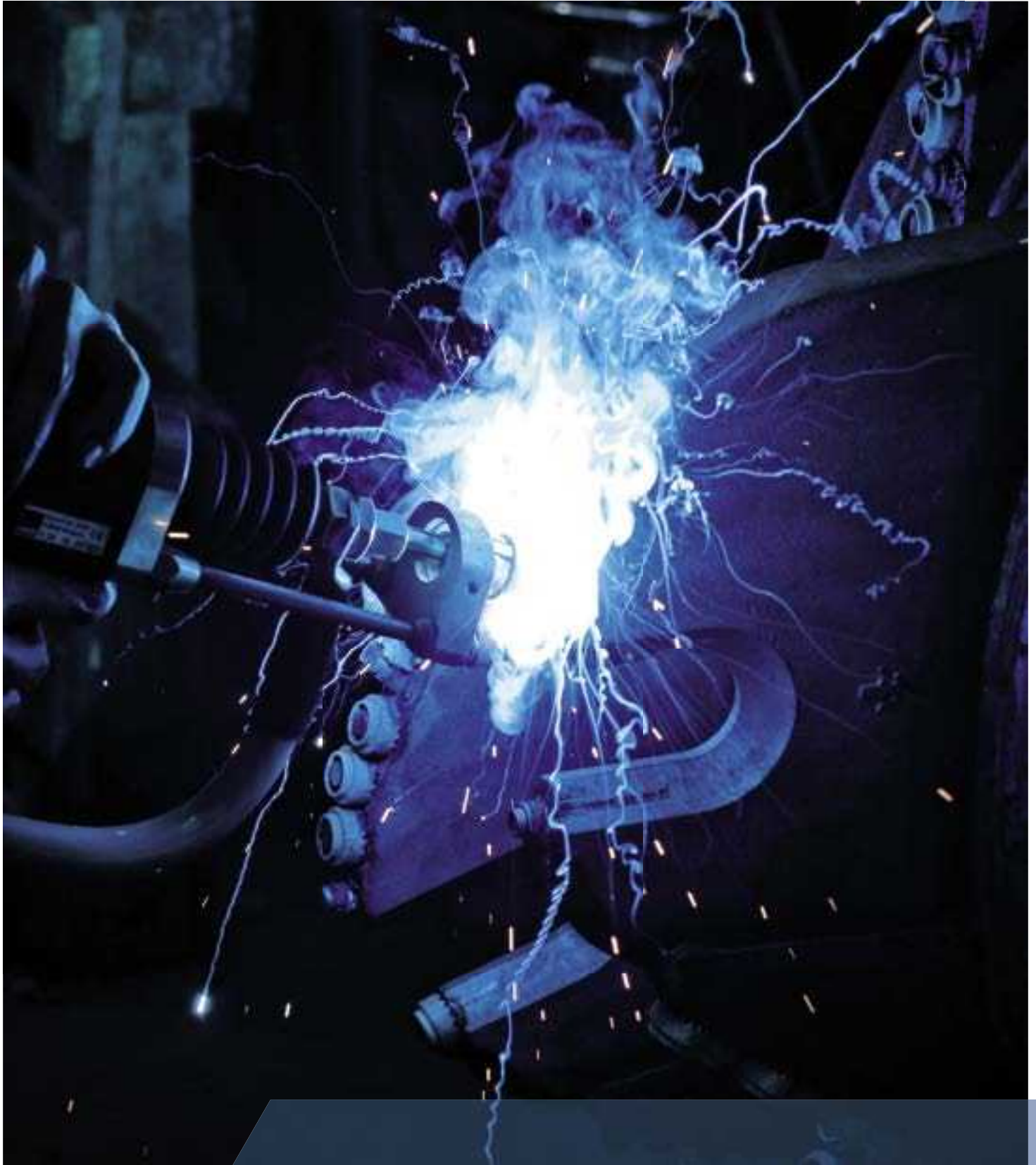



➤ BETEK

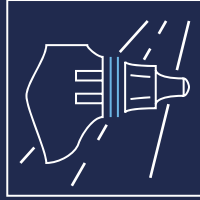

SURFACE TECHNOLOGIES

- ROAD MILLING
- SURFACE MINING
- STABILISING
- RAIL TRACK CONSTRUCTION
- CRUSHING & MIXING



UNDERGROUND TECHNOLOGIES

- FOUNDATION DRILLING
- MINING
- TRENCHLESS
- TRENCHING
- TUNGSTUDS
- DRUM CUTTERS

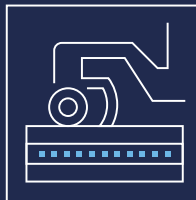

ENVIRONMENTAL TECHNOLOGIES

- AGRICULTURE
- GRADER TOOLS
- TUNGSTEN CARBIDE
- FORESTRY & RECYCLING

Service number
+49 (0) 7422. 565-0

info@betek.de
www.betek.de